

THERMAL SLEEVE

1 LITER BOTTLE WRAP

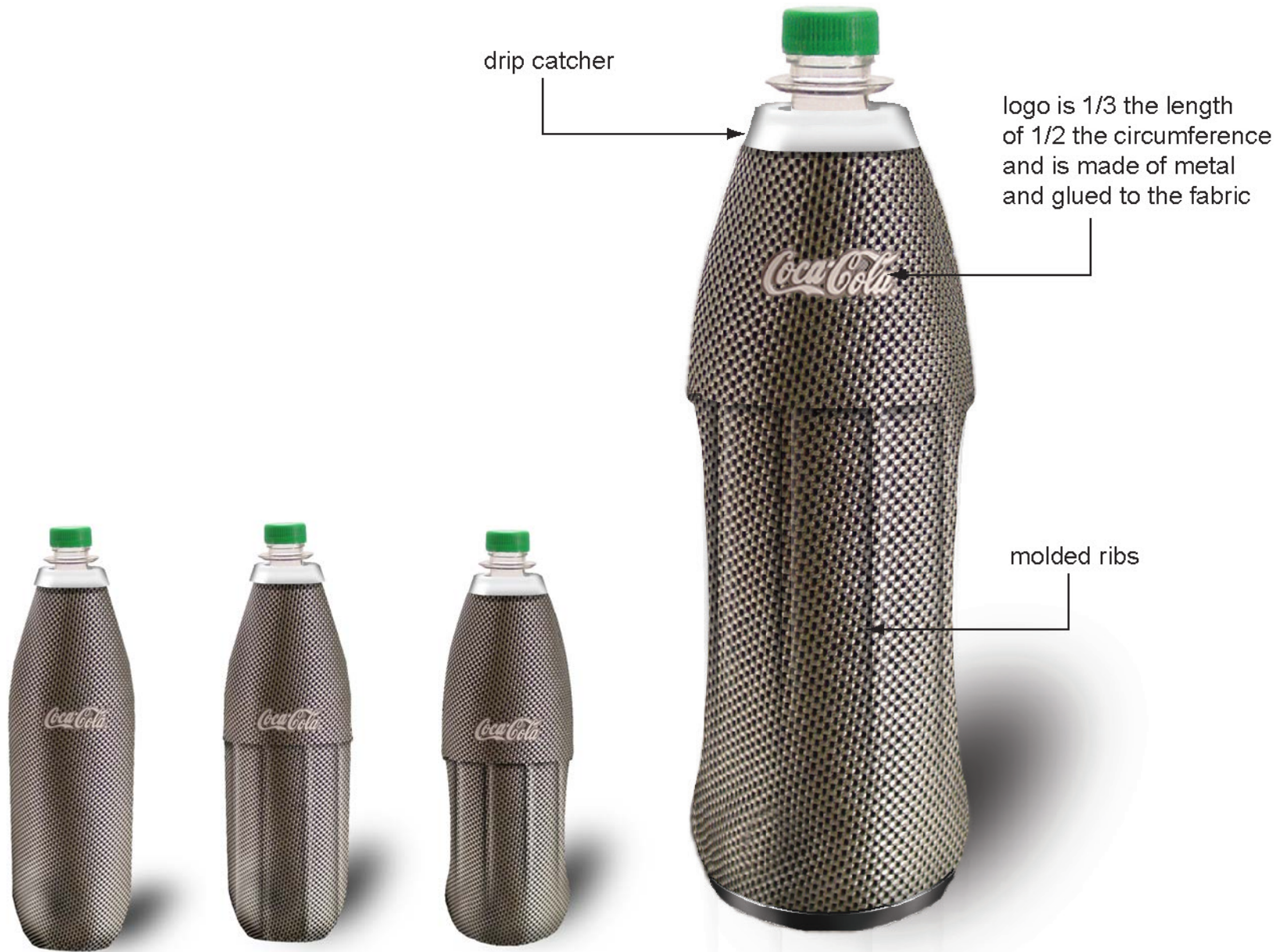

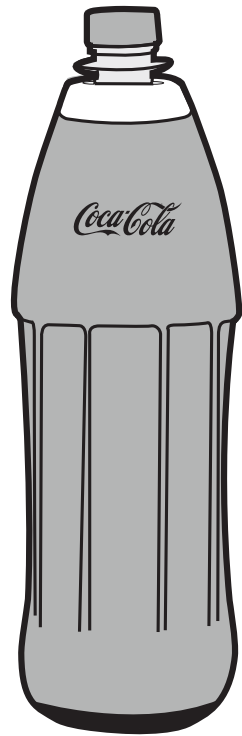



front

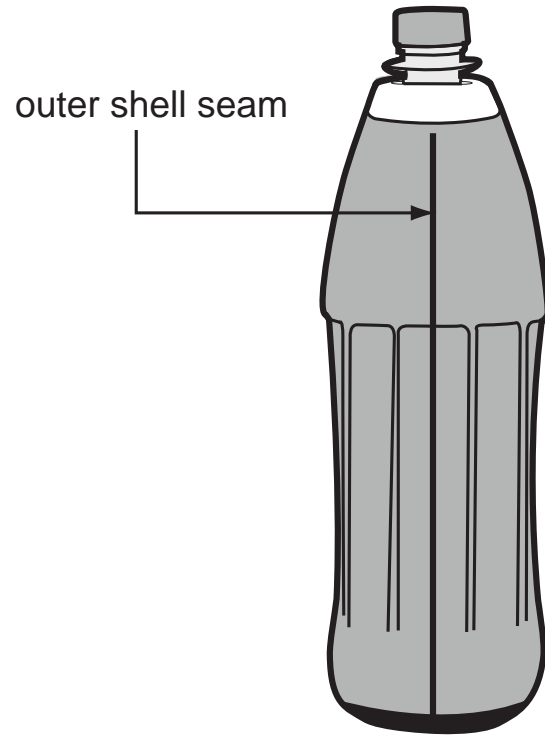

right side

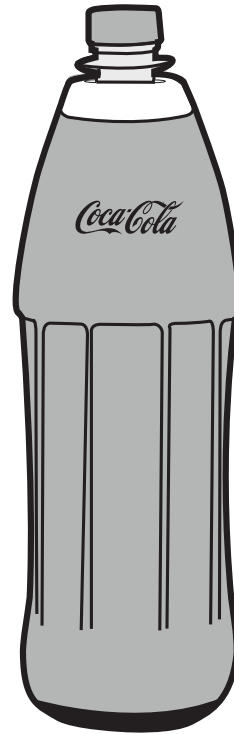

back

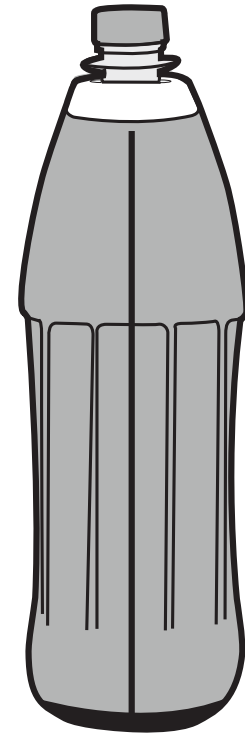

left side

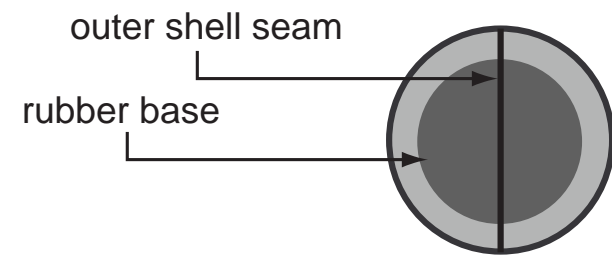

bottom

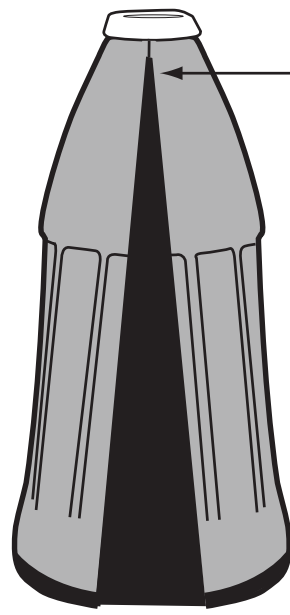

hard shell stops 1/2
inch from top
to allow hard shell
to pivot out.

expanded shell with
neoprene exposed

1.



2.

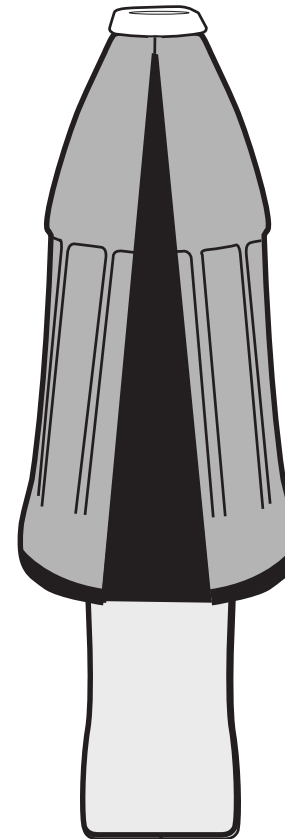

3.

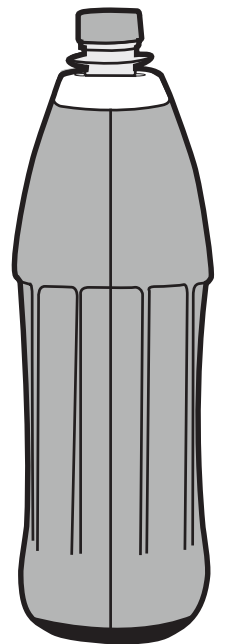

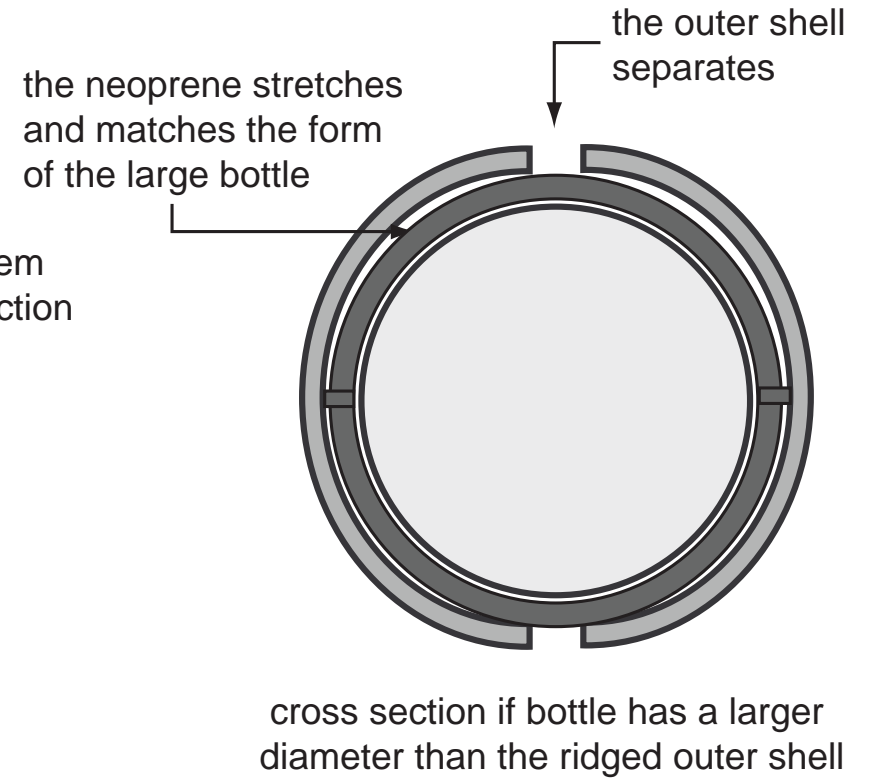
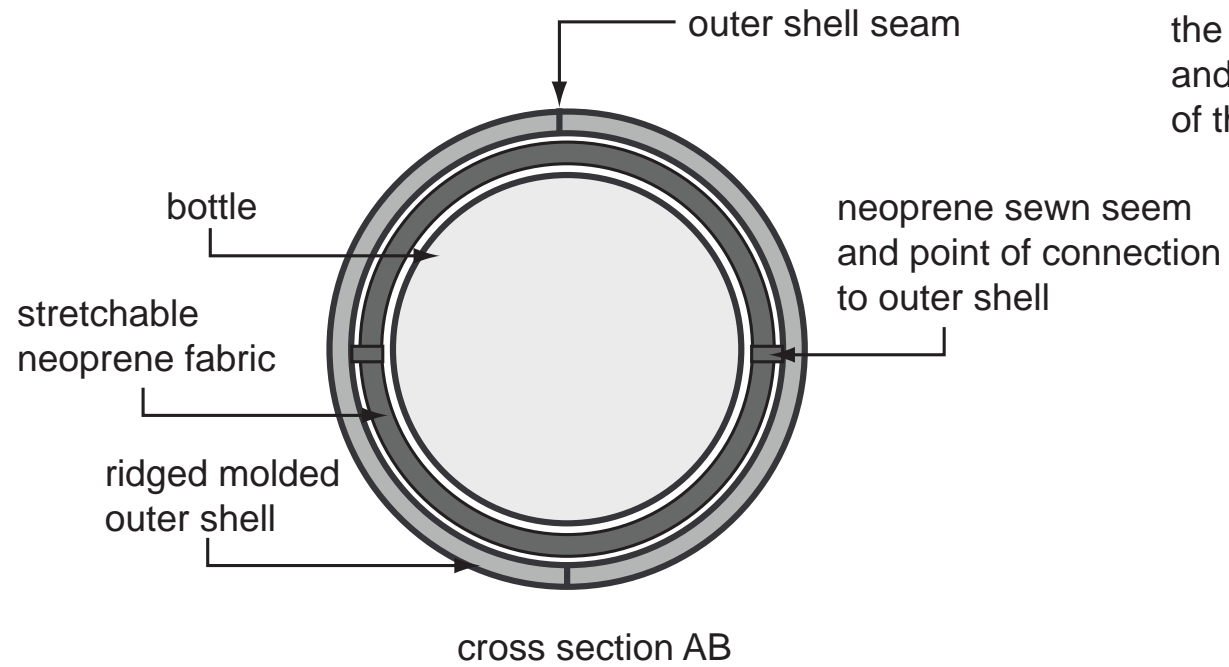
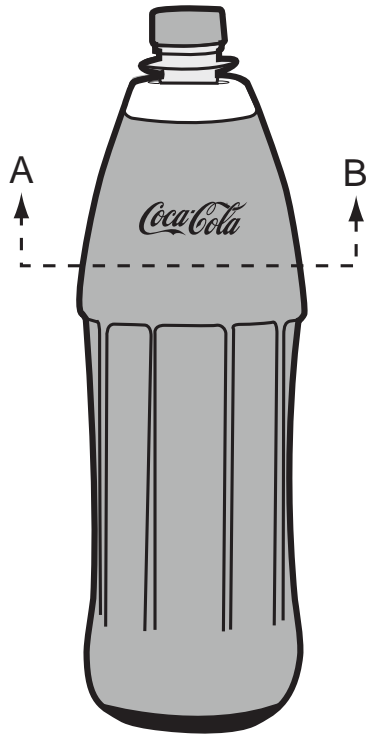

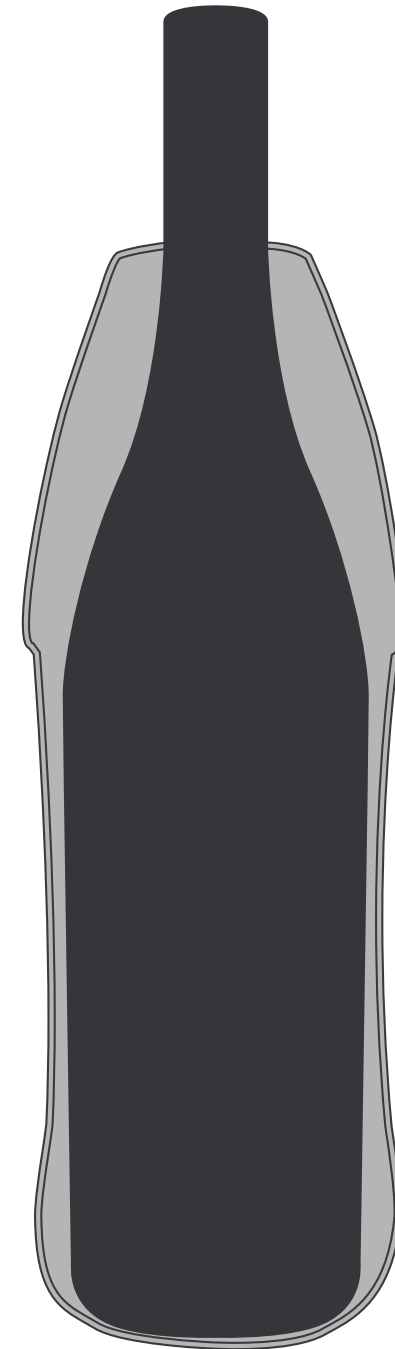
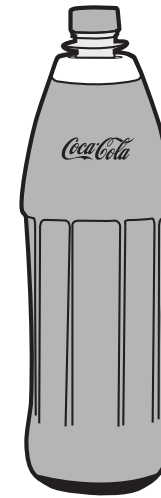

Because of the hard shell, this concept holds its form, even if the bottle inside (such as a wine bottle) does not support the shape.